



Rudarstvo i bušenje tunela
Mining and tunnelling



VORAX

experts in wear resistant technologies

BETEK

Progress!



Alati	str.
Šiljci za glodanje (zubi) prihvata Ø14 mm / Round shank cutter bits	3
Šiljci za glodanje (zubi) prihvata Ø19,4 mm / Round shank cutter bits	3-4
Šiljci za glodanje (zubi) prihvata Ø22 mm / Round shank cutter bits	5
Šiljci za glodanje (zubi) prihvata Ø25 mm / Round shank cutter bits	6-9
Šiljci za glodanje (zubi) prihvata Ø30 mm / Round shank cutter bits	10-14
Šiljci za glodanje (zubi) prihvata Ø35 mm / Round shank cutter bits	15-16
Šiljci za glodanje (zubi) prihvata Ø38 / 30 mm / Round shank cutter bits	17-19
Šiljci za glodanje (zubi) prihvata Ø38 mm / Round shank cutter bits	20-22
Šiljci za glodanje (zubi) sa specijalnim prihvatom / Special shank cutter bits	23
Šiljci za glodanje (zubi) prihvata Ø38 mm tip Krummenauer	24
Šiljci za glodanje (zubi) prihvata Ø40 mm tip Krummenauer	24
Šiljci za glodanje (zubi) prihvata Ø43 / 35 mm / Round shank cutter bits	25-26
Radijalne oštrice. Krilasti zubi / Radial pic, Wing bit	27
Iskop smjernih potkopa (mikrotuneliranje) / Microtunnelling	28-29
TBM alati (alati za strojeve za bušenje tunela) / Tools for TBM	30
Vijci za zavarivanje s jezgrom od tvrdog metala / TungStuds	31

Ispod slika alata naći ćete
slijedeće informacije:

→ **Art-No (kat.br)**
→ Opis



← Kom. u pakiranju

Dimenzije: mm / inch

Za upute za zavarivanje provjerite:

www.vorax.hr ili www.betek.de/en/productprogramme/mining-tunneling-userinfo.html



PODRŠKA:

Vorax d.o.o.
Vukovarska 68, Rijeka, HR
T: + 385 51 493 893
info@vorax.hr
www.vorax.hr

Prihvat Ø14 mm - 0,55"

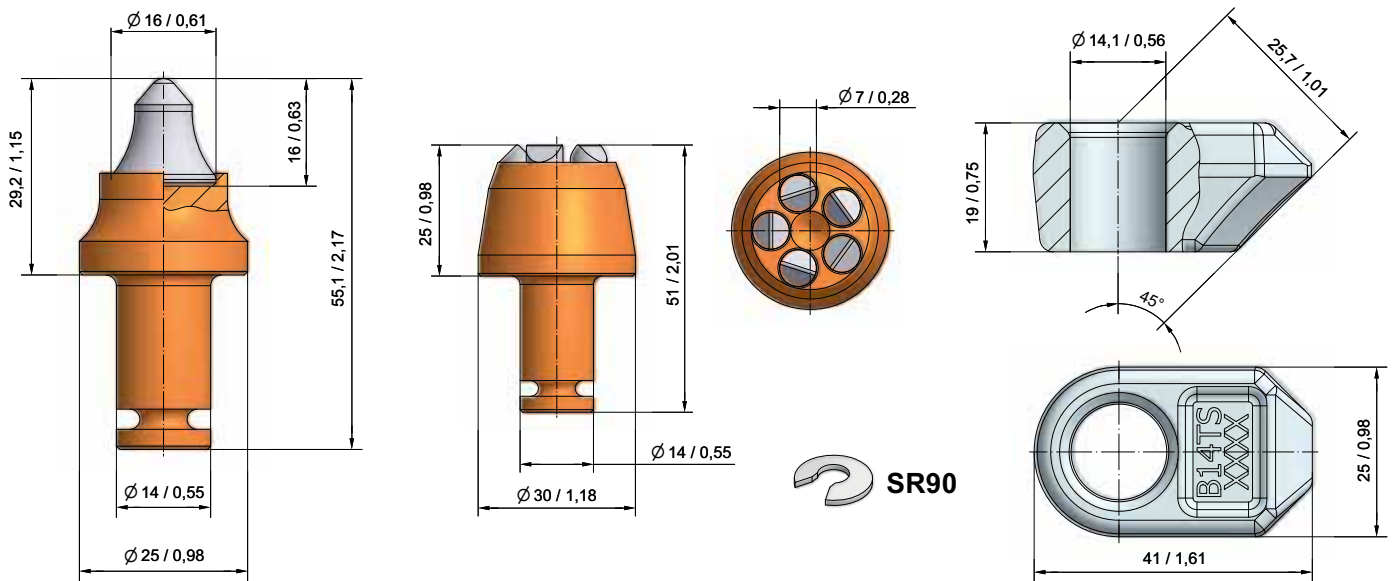

BM76 200
BM4-14 / TS

BM69 150
BM7-14 / 2F

BHR171 200
B14TS

Prihvat Ø19,4 mm - 0,76"

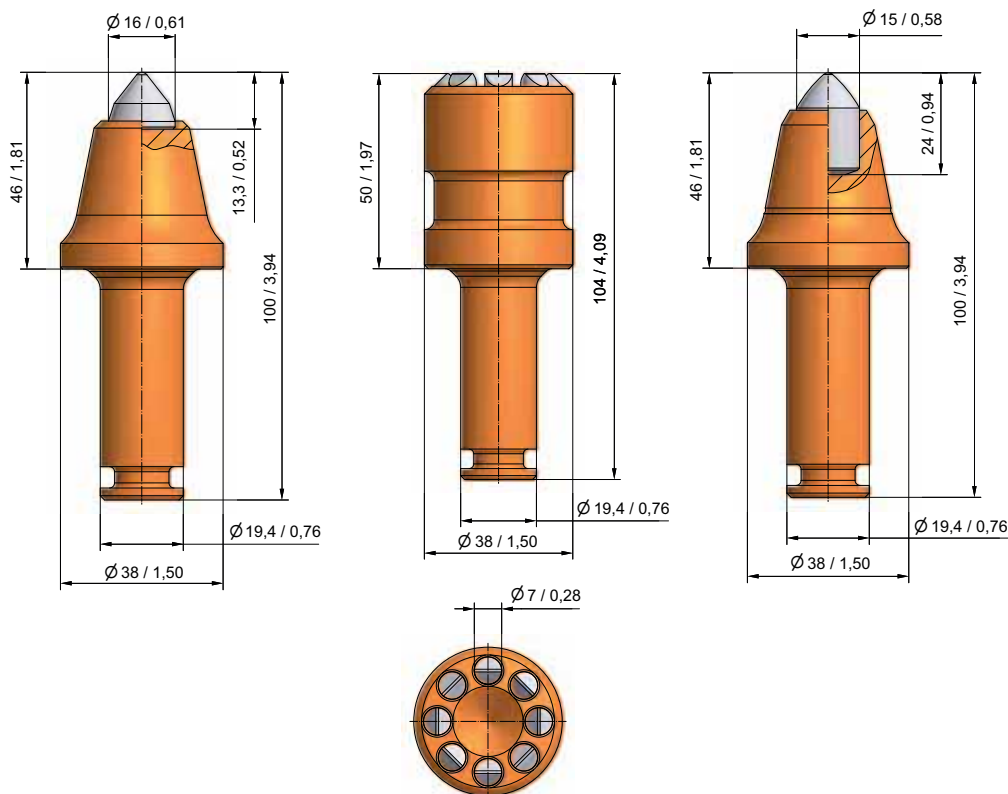

BC26 40
B3KS

BSR63 20
BG20F-07.3850

BC68 40
BG20F-15.3846

Prihvat Ø19,4 mm - 0,76"

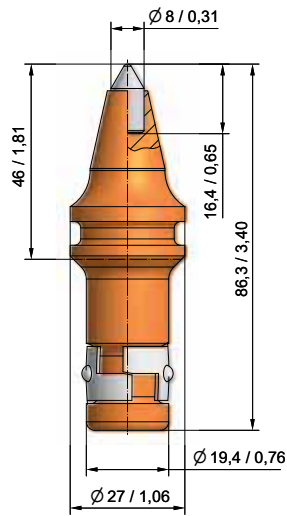

BSK19
B1K8-K

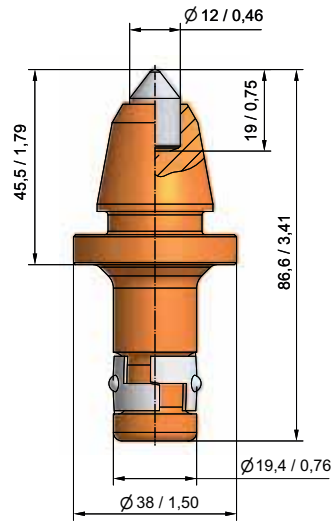

BSK21
B1-12 / 38-K



Prihvat Ø19,4 mm - 0,76"

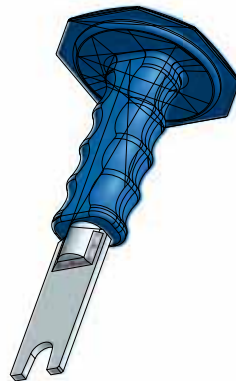

BZ33
Alat za montažu

BZ31
Alat za demontažu

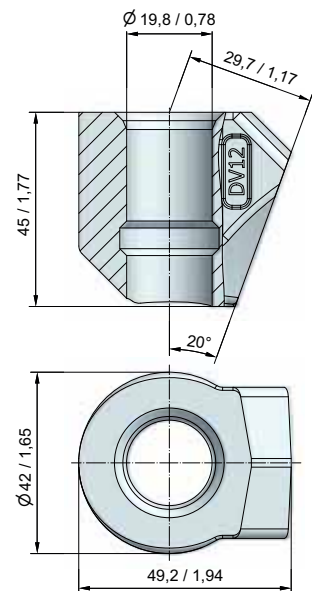

BHR143
DV12 / 2



Prihvat Ø22 mm - 0,87"

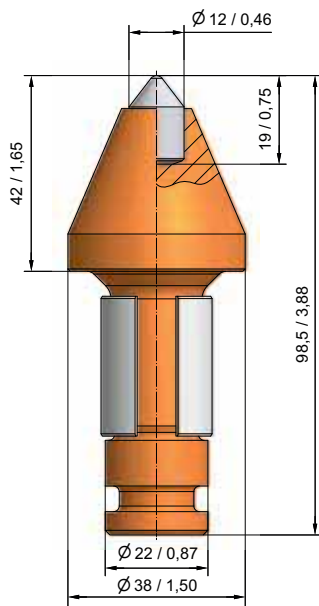

BC36

40

B1-12 / 22 / SI26

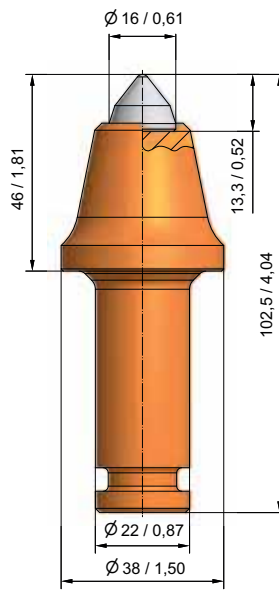

BC33

40

B3KS22

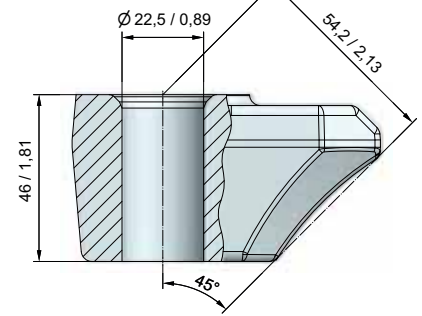

BHR120OL

20

B22S

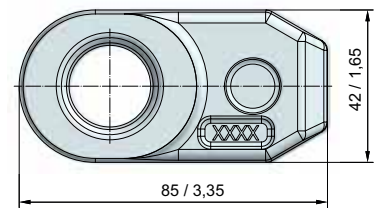

Prihvat Ø22 mm - 0,87"



SI26

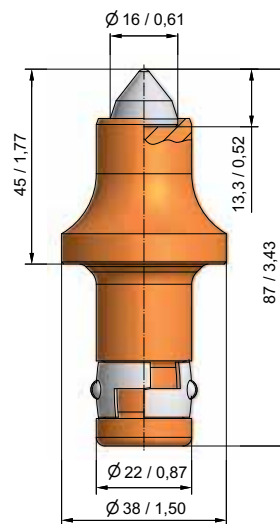

BC58

50

B3S / 22-K

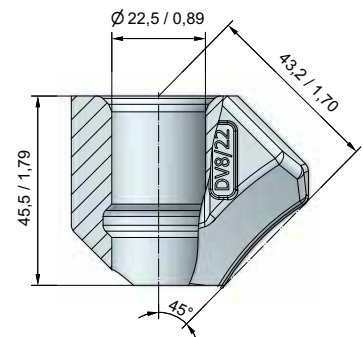

BHR176

40

DV8 / 22-K

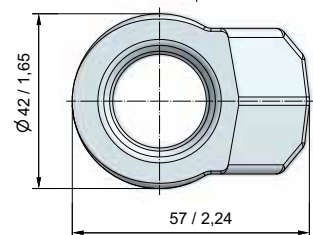

BZ41

Alat za montažu

BZ32

Alat za demontažu

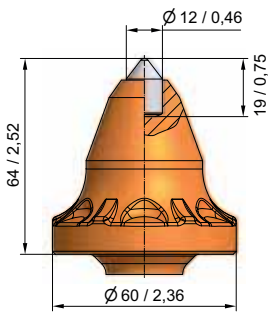

BTK114
BG25F-12.6064



15

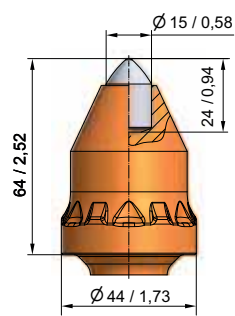

BTK117
BG25F-15.4464



15

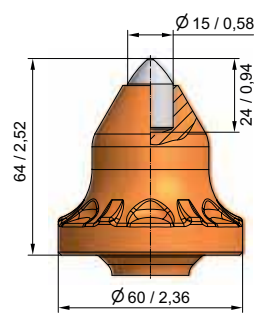

BTK120
BG25F-15.6064



15

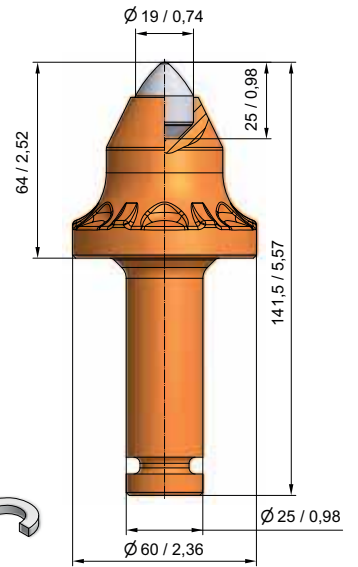

BTK122
BG25F-19.6064



15

SI79 / K

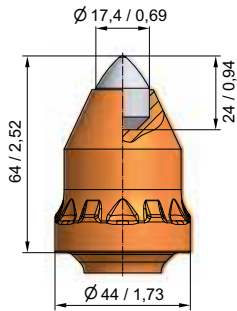

BTK116
BG25F-17.4464



15

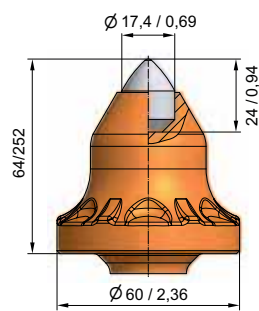

BTK121
BG25F-17.6064



15

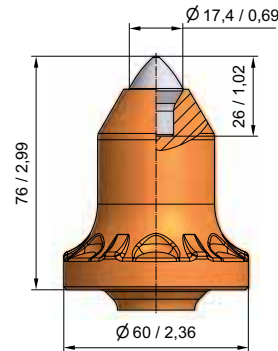

BTK126
BG25F-70.6076A



15

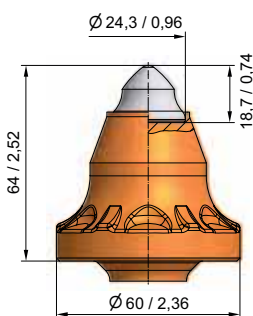

BTK124
BG25F-68.6064



15

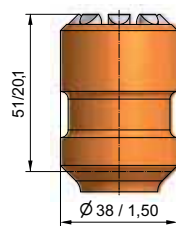

BSR78
BG25F-07.3851



15

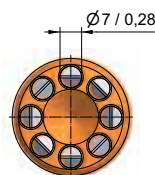

Prihvat Ø25 mm - 1"

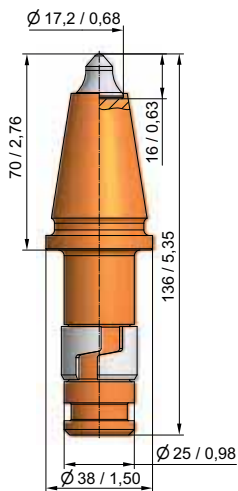

BTK108
BG25HP-62.3870

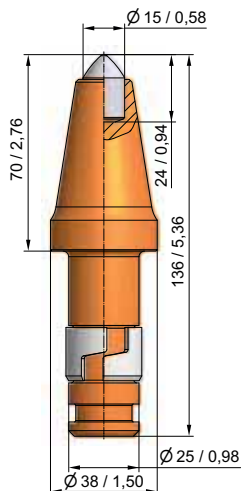

BTK110
BG25HP-15.3870

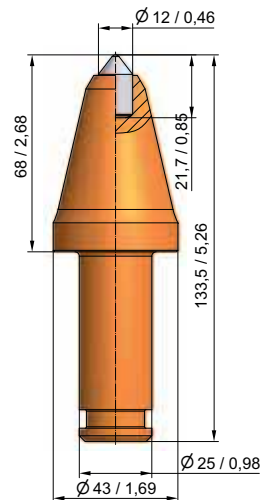

BTK53
B40K12

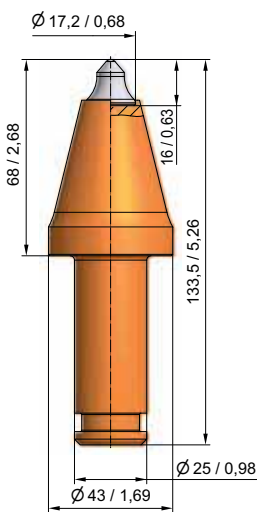

BTK109
BG25P-62.4368

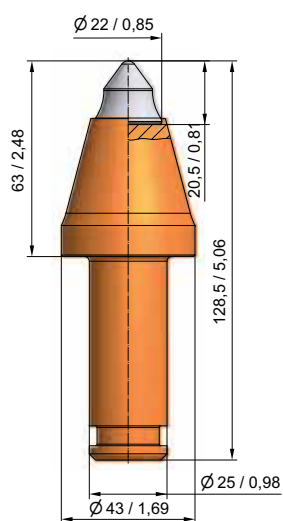

BTK107
BG25P-74.4363



SI184

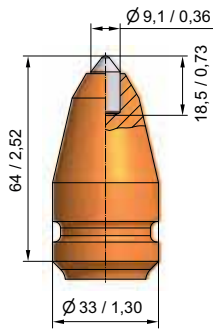

BTK01
B40K9

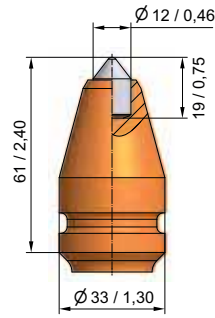

BTK03
B40HDK12

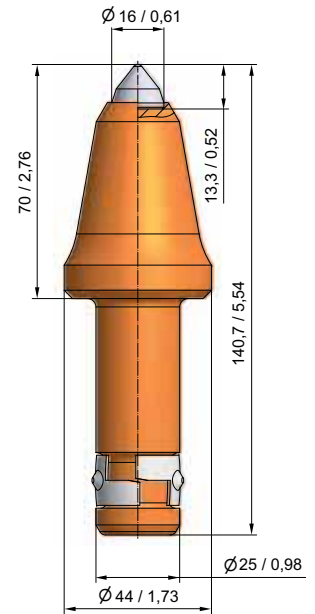

BTK99
B40 / 3-LSK



SI79 / K

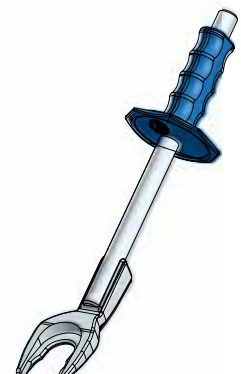

BZ37

Alat za montažu

BZ36

Alat za demontažu

BZ43

Izbijač zuba

BZ22

Alat za vađenje zuba



Prihvat Ø25 mm - 1"

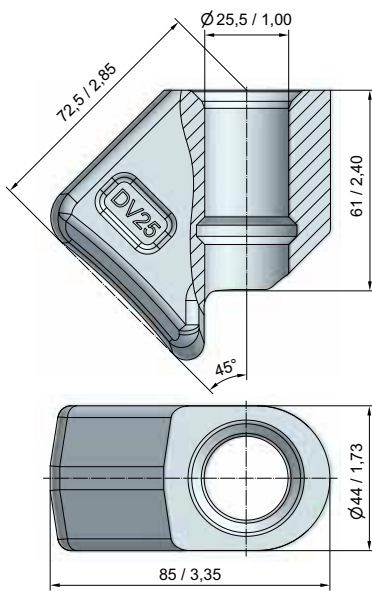

BHR31
DV25

15

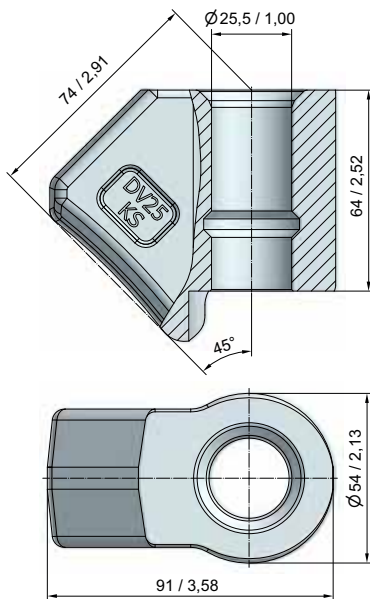

BHR121
DV25KS

10

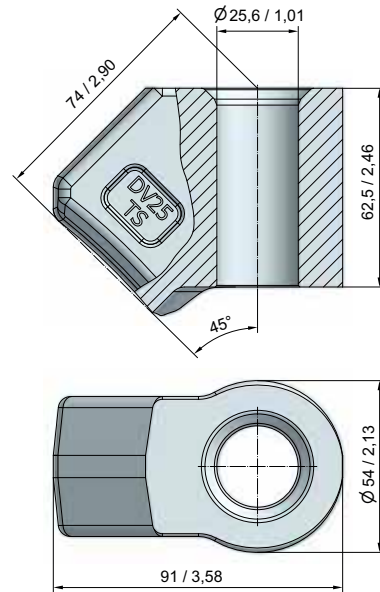

BHR145
DV25TS

10

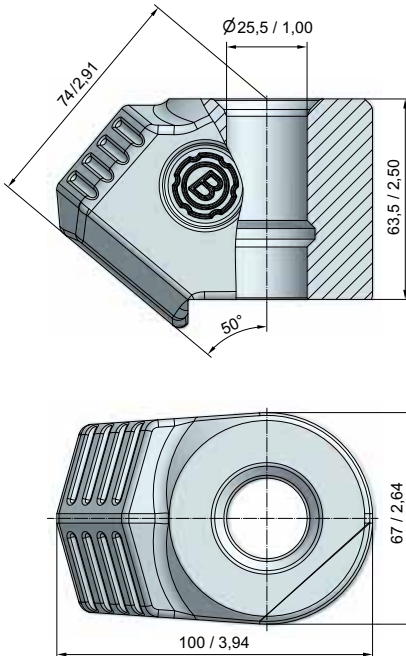

BHR186
B25.6750

6

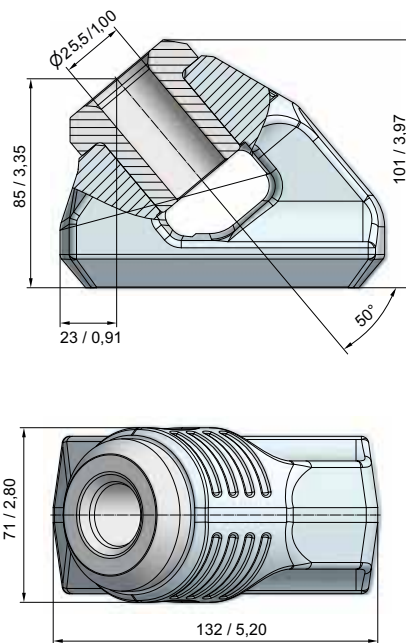

BHR185
B132-101-B

3

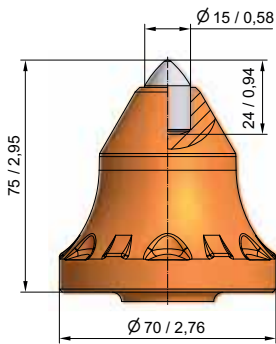

BGF25
BG30F-15.7075

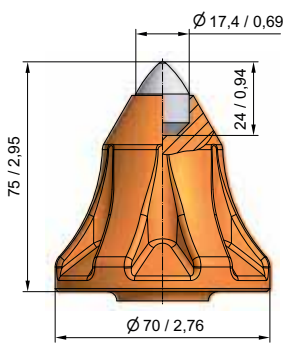

BGF10
B47GK17.5LK75-E/F

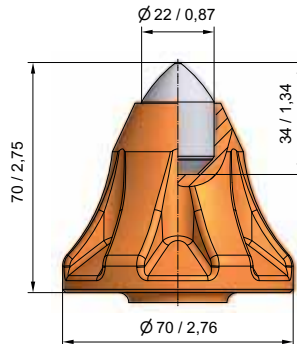

BGF11
B47GK22LK70-E/F

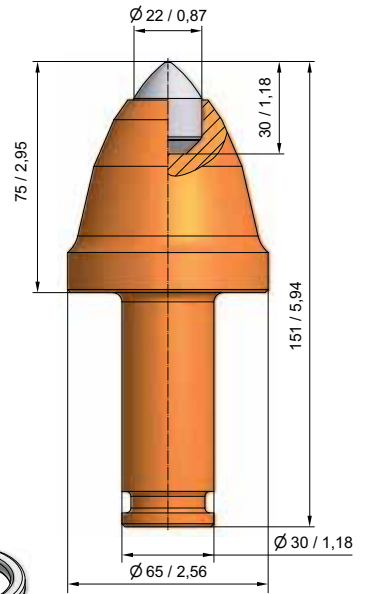

BGF09
B47GK22LK75/65



SI35 / 22

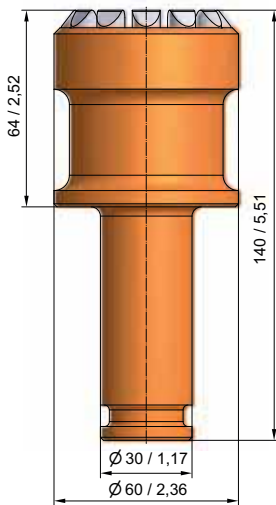

BSR58
BG30F-09.6064

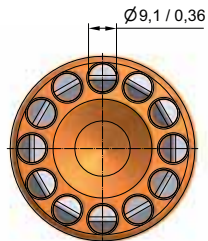

Prihvat Ø30 mm - 1,18"

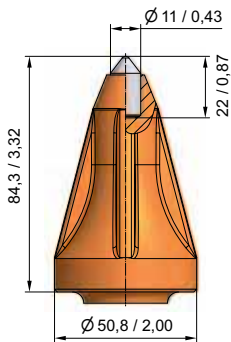

BGF14
BG30P-11.5184

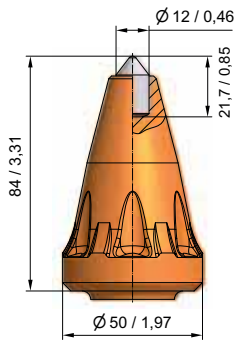

BGF21
BG30P-12.5084A

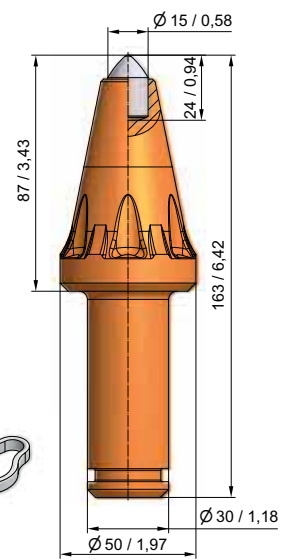

BGF22
BG30P-15.5087

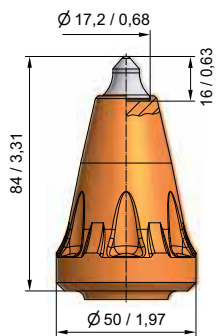

BGF19
BG30P-62.5084A

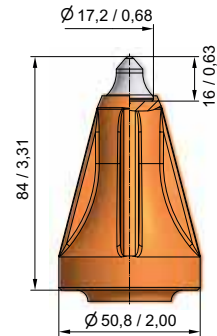

BGF17
BG30P-62.5184

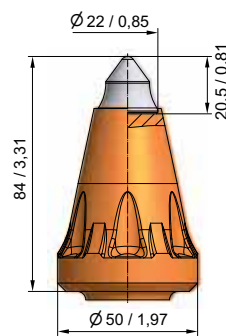

BGF26
BG30P-74.5084



Prihvat Ø30 mm - 1,18" duljine 82 mm

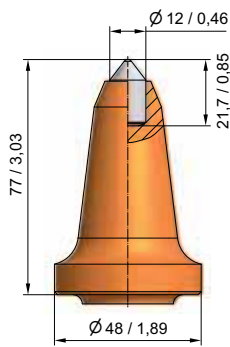

BGK06

15

B47GK12LK77-K

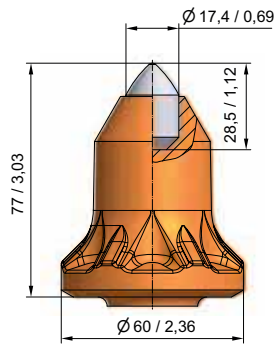

BGK86

10

B47GK17.5LK77-KE

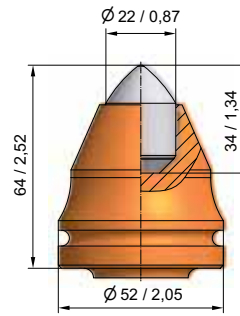

BGK38

10

B47GK22-K

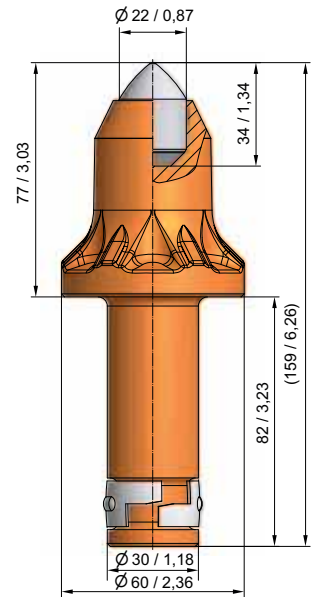

BGK90

10

BG30K-22.6077

Prihvat Ø30 mm - 1,18" duljine 76 mm

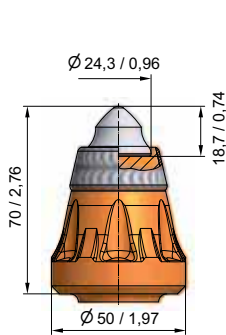

BGK91

15

BG30K-68.5070P

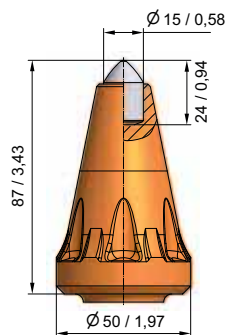

BGK88

15

BG30K-15.5087

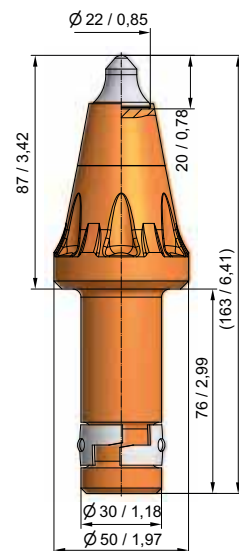

BGK89

15

BG30K- 67.5087

Prihvat Ø30 mm - 1,18"

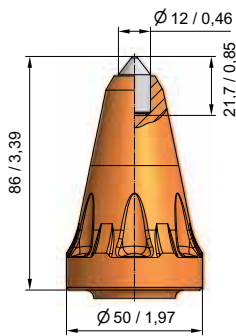

BGS101
BG30W-12.5086

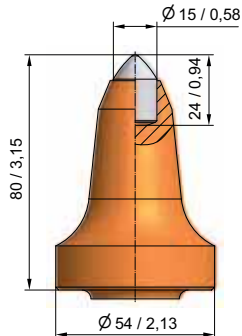

BGS95
B47GK15LK80

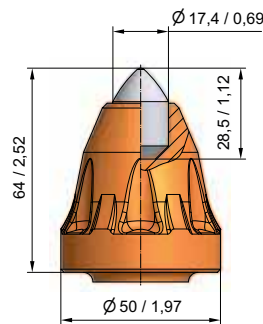

BGS102
BG30W -17.5064

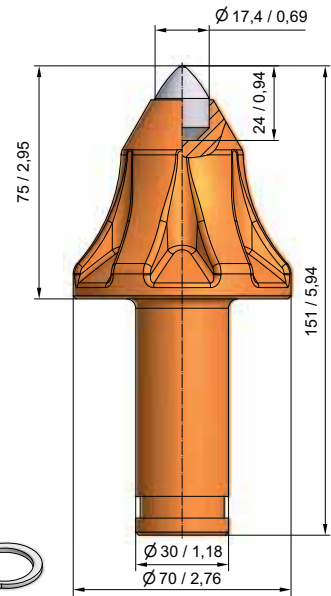

BGS89
B47GK17.5LK75-E

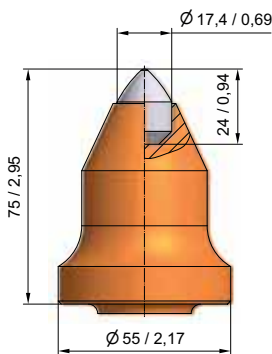

BGS80
B47GK17.5LK75

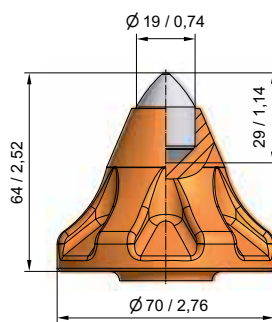

BGS88
B47GK19 / 70-E

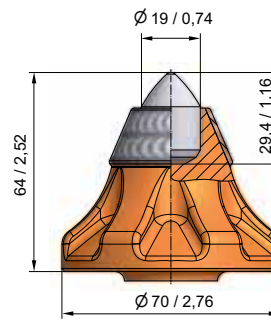

BGS84
B47GK19 / 70-P

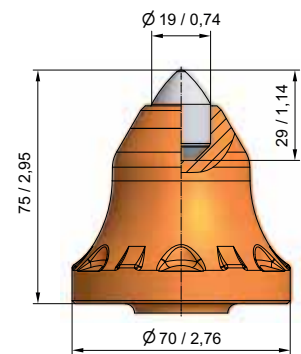

BGS100
BG30W-19.7075

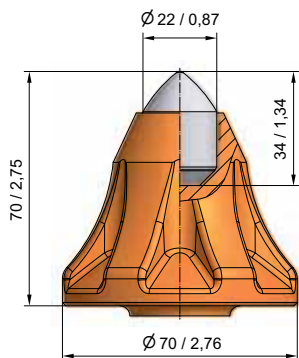

BGS90
B47GK22LK70-E

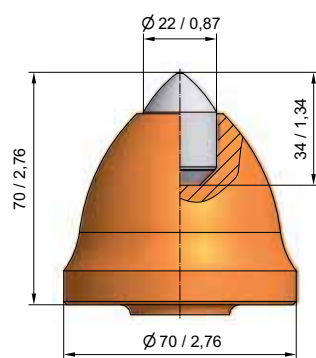

BGS93
B47GK22LK70 / 70

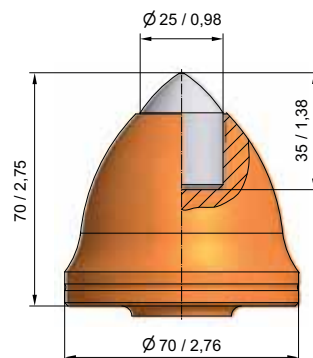

BGS16
B47GK25LK70 / 70

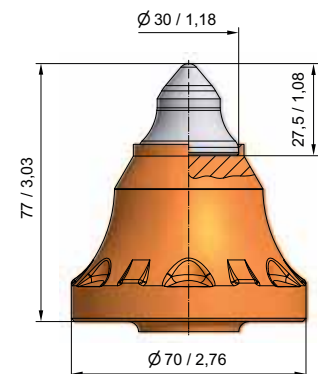

BGS103
BG30W-69.7077



Prihvat Ø30 mm - 1,18"

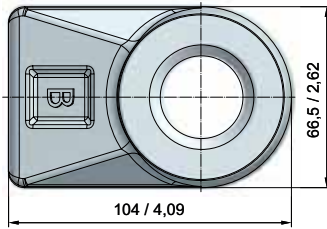
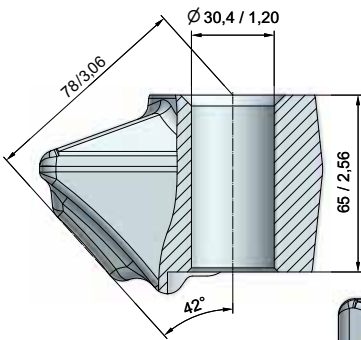

BHR35
B30.65

5

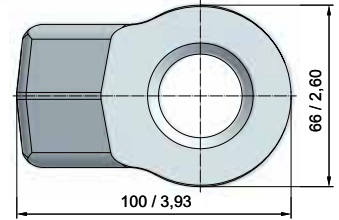
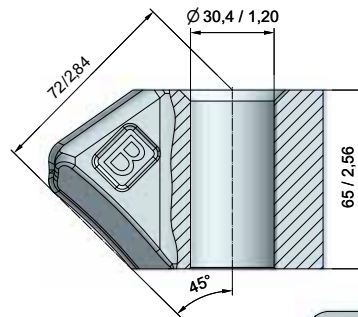

BHR94
B43G

5

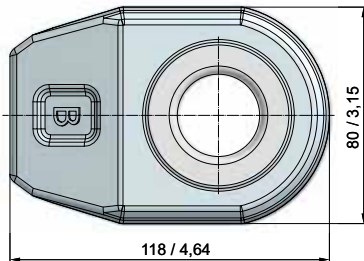
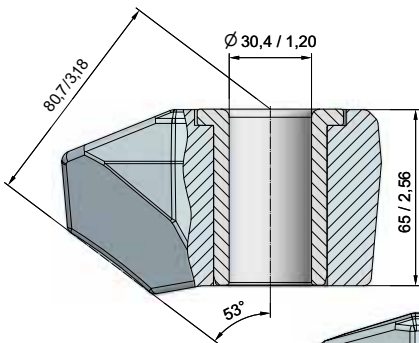

BHR75
B30.65H

5

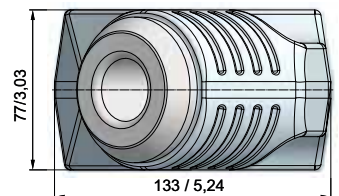
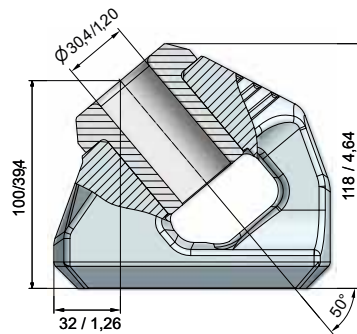

BHR183
B133 -118 - B

1



BZ39
Alat za vađenje klinova



BZ35
Alat za montažu



BZ34
Alat za demontažu

SI35 / 22

Prihvat Ø35 mm - 1,38", visina glave 89 mm / 3,5"

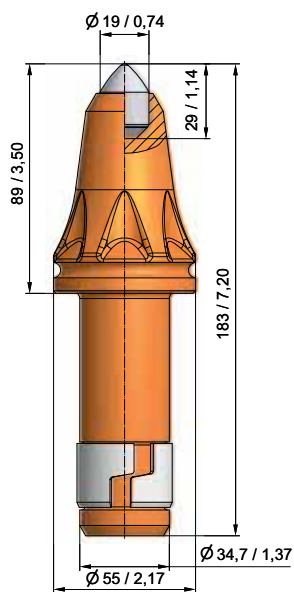

BSR111
BG35H -19.5589A

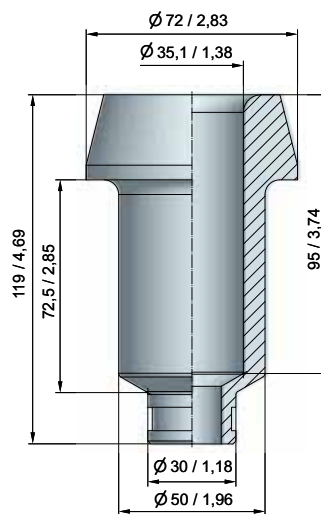

BR71
BR49.8 -35 -119



Prihvat Ø35 mm - 1,38", visina glave 89 mm / 3,5"

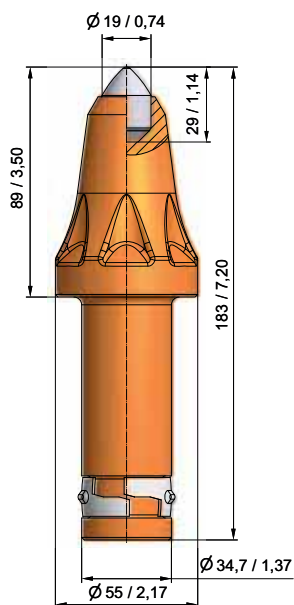

BSR112
BG35K-19.5589

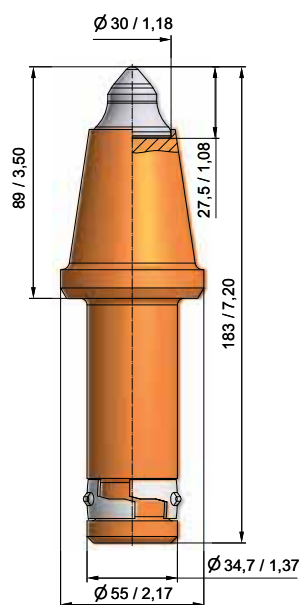

BSR121
BG35K- 69.5589



Prihvat Ø35 mm - 1,38" visina glave 100 - 102 mm / 4"

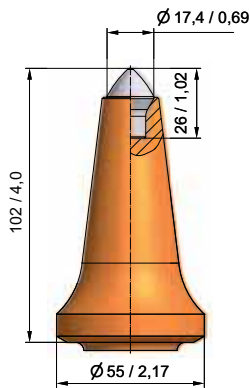

BSR150

10

BG35H -70.55102

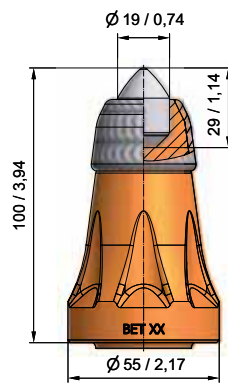

BSR146

10

BG35H -19.55100P

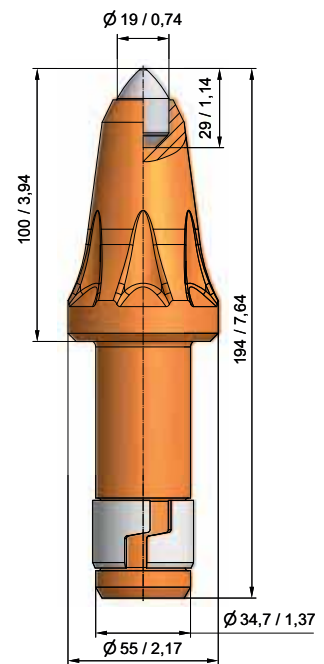

BSR175

10

BG35H -19.55100

Prihvat Ø35 mm - 1,38" visina glave 100 - 102 mm / 4"

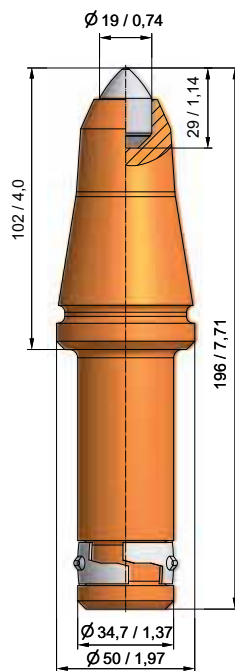

BSR97

10

BG35K-19.50102

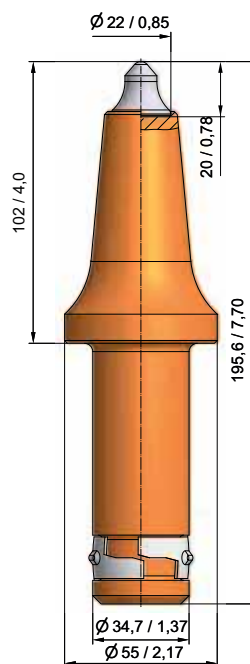

BSR126

10

BG35K- 67.55102



BZ39

Alat za vađenje klinova

Prihvat Ø38 / 30 mm - 1,5 / 1,18"

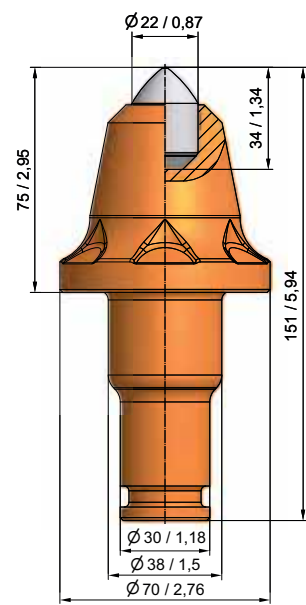
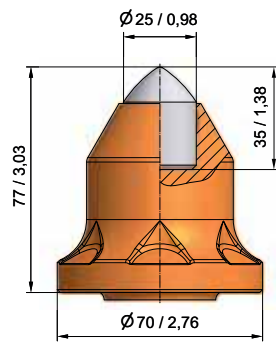
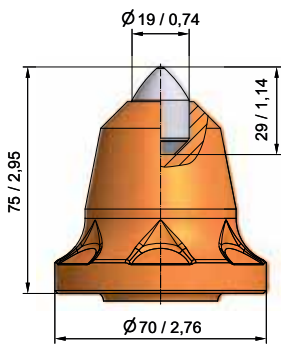

BK15
B47K19 / 70-F



BK10
B47K25-F



BK17
B47K22 / 70-F

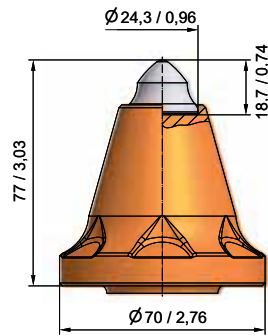
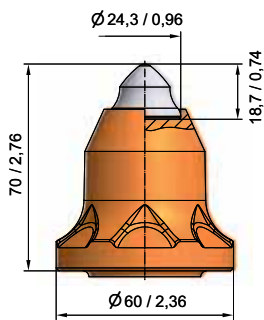

BK13
B47K24LK70-FE



BK16
B47K24 / 70-F

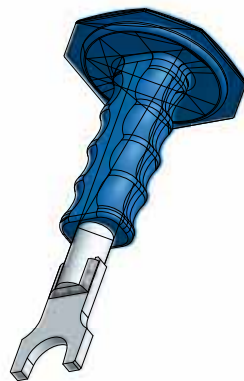
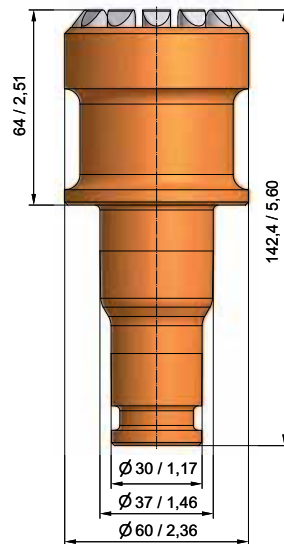

SI 35 / 22

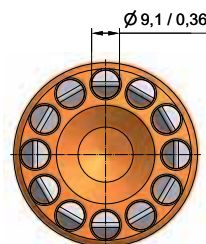

BZ35
Alat za montažu

BZ34
Alat za demontažu

BSR103
BS37F- 09.6064



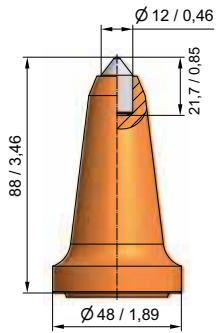

BKS16
B46K12LK90

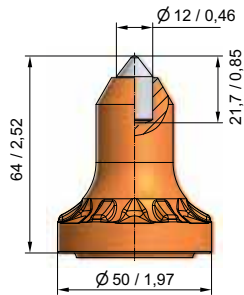

BKS184
BS38W-12.5064

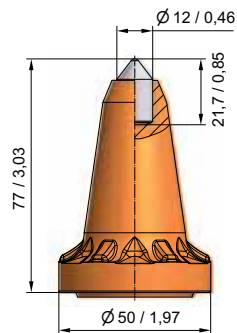

BKS153
BS38W-12.5077

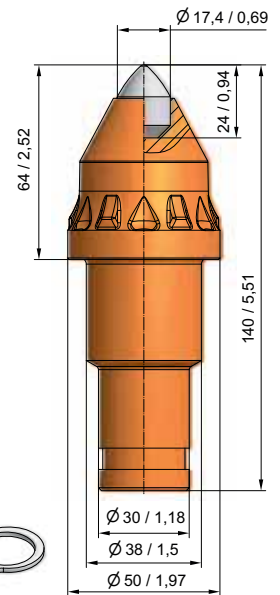

BKS155
BS38W-17.5064



SR83 

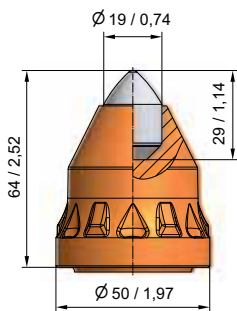

BKS154
BS38W-19.5064

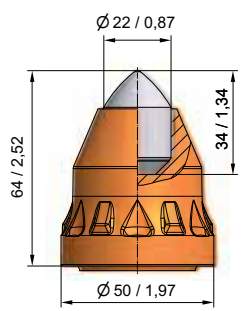

BKS156
BS38W-22.5064

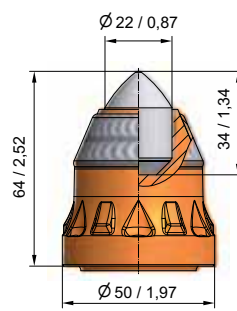

BKS156 / P
BS38W-22.5064P



Prihvat Ø38 / 30 mm - 1,5 / 1,18"

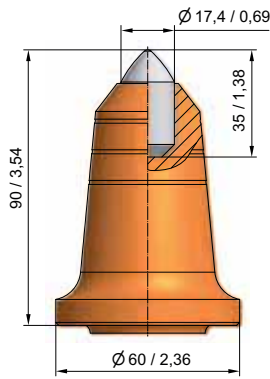

BKS157 10
W49K17 / S

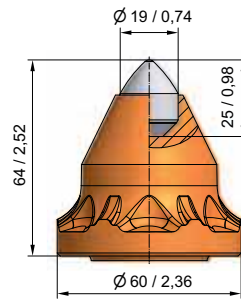

BKS151 10
BS38W -19.6064

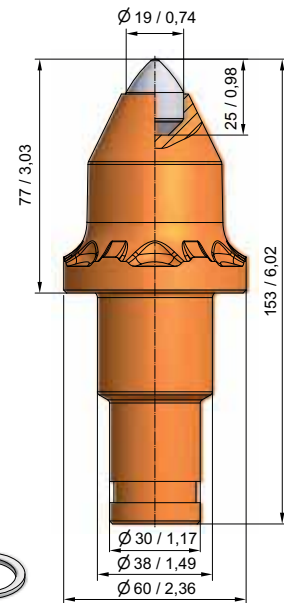

BKS172 10
BS38W -19.6077

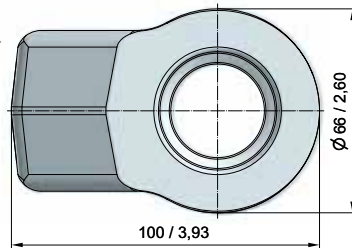
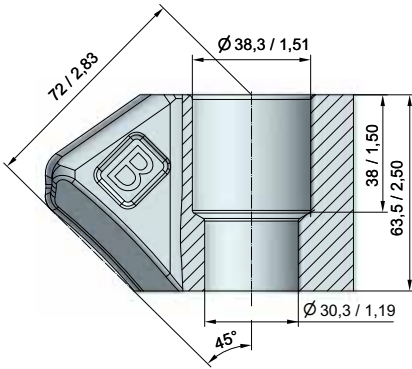

BHR38 10
B43H



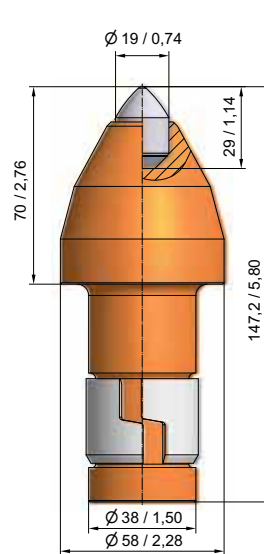

BSR158
BG38H -19.5870

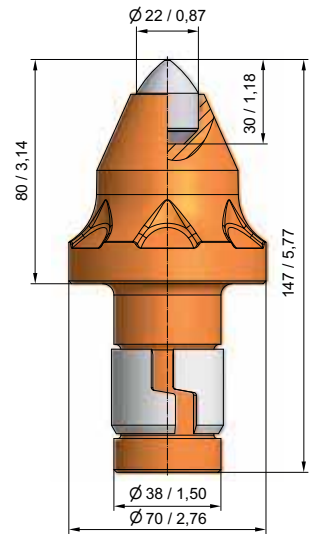

BSR196
BG38H -22.7080

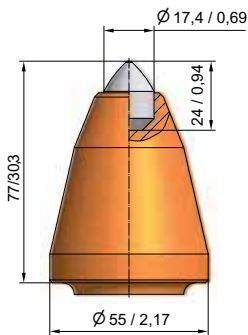

BSR94
BG38K-17.5577

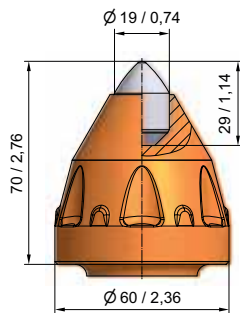

BSR188
BG38K-19.6070

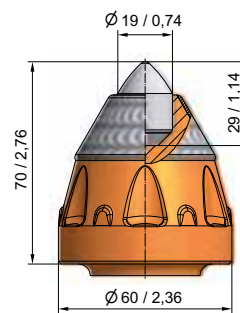

BSR202
BG38K-19.6070P

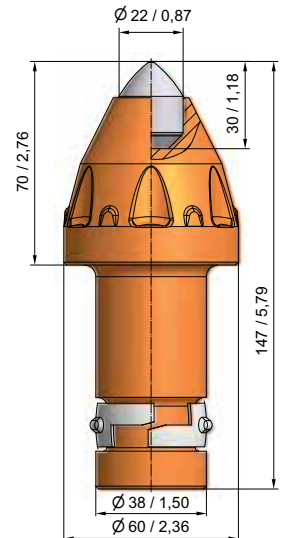

BSR189
BG38K-22.6070

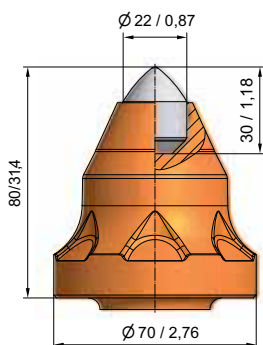

BSR125
BG38K-22.7080A

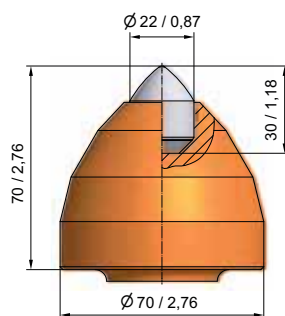

BSR133
BG38K-22.7070

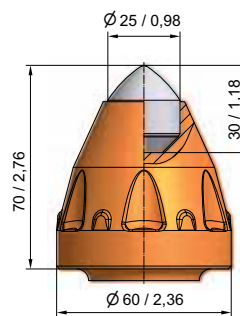

BSR190
BG38K-25.6070

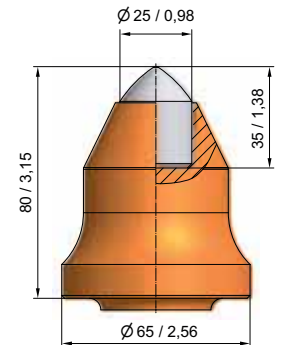

BSR160
BG38K-25.6580



Prihvat Ø38 mm - 1,5" duljine prihvata 65 mm / 2,6"

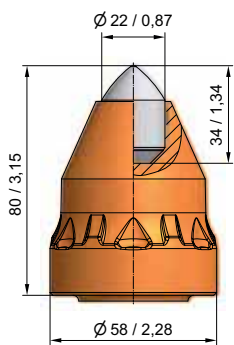

BSR174
BG38W-22.5880A

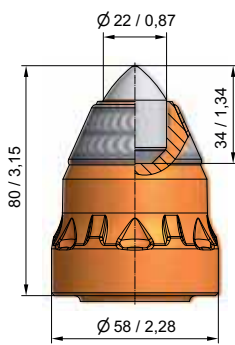

BSR180
BG38W-22.5880PA

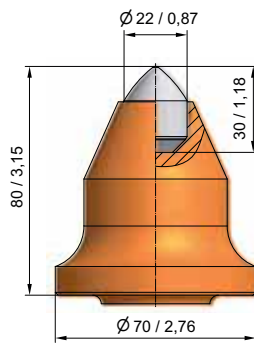

BSR140
BG38W-22.7080

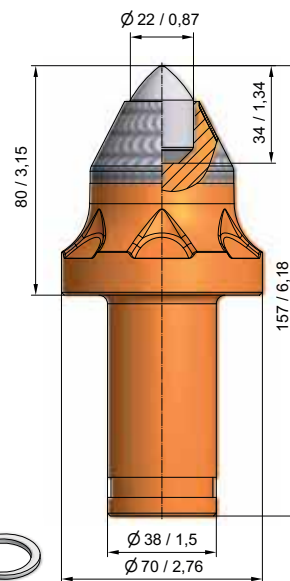

BSR199
BG38W-22.7080AP



SR65 / 2.5

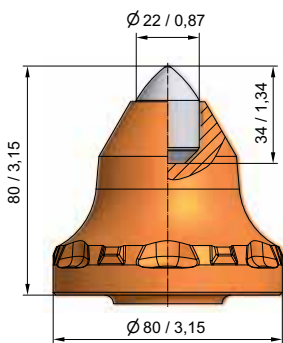

BSR198
BG38W-22.8080A

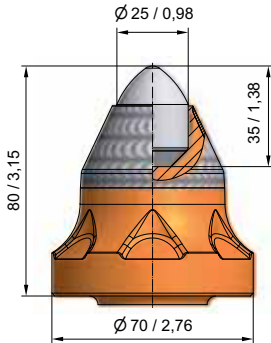

BSR200
BG38W-25.7080P

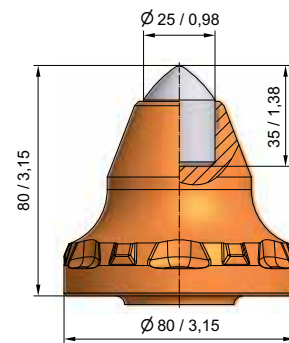

BSR201
BG38W-25.8080A

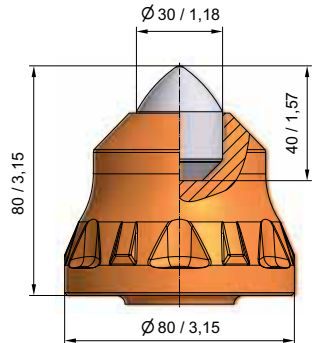

BSR197
BG38W-30.8080A

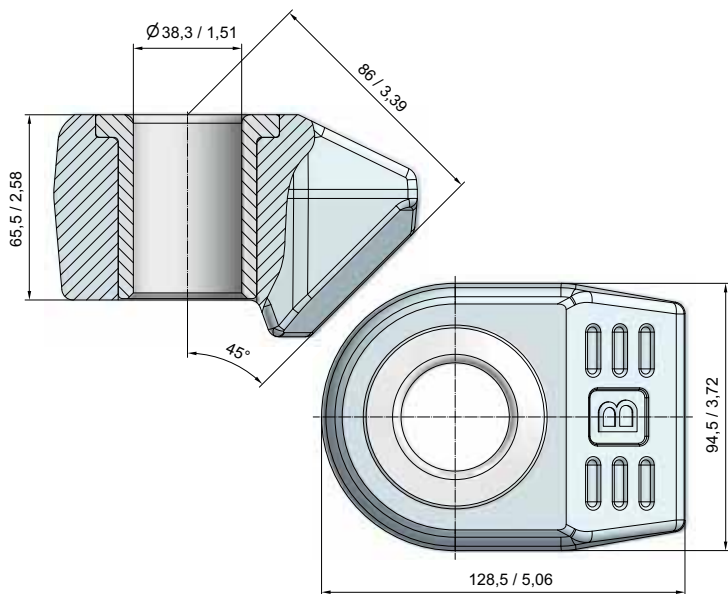

BHR169
B38H



Prihvat Ø38 mm - 1,5" duljine prihvata 75 mm / 3,0"

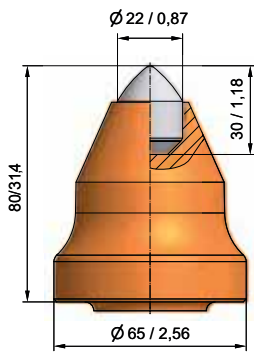

BSR114
BG38W-22.6580A

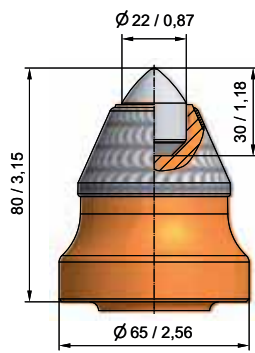

BSR131
BG38W-22.6580P

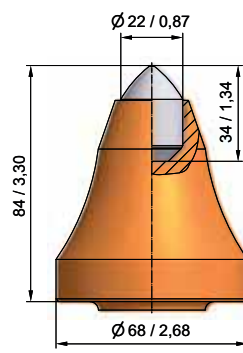

BSR05
BG38W-22.6884

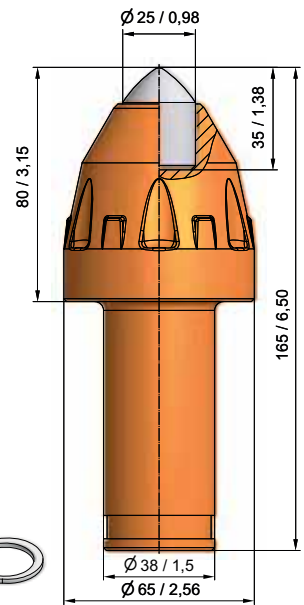

BSR193
BG38W-25.6580A



SR65 / 2.5



Specijalni prihvat

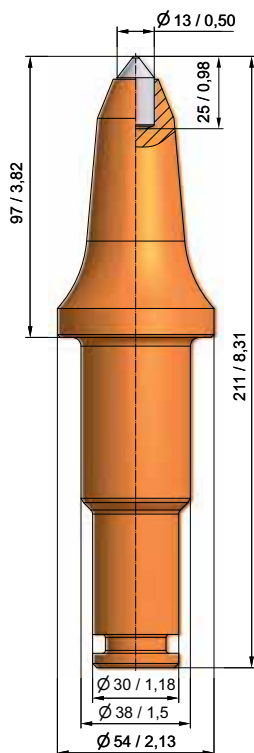

BKF14
B47K13LK97L

8

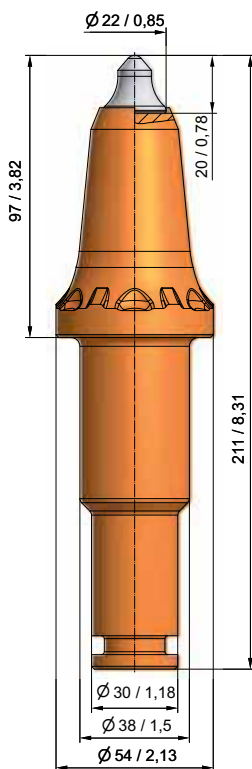

BKF23
BS38F-67.5497

8

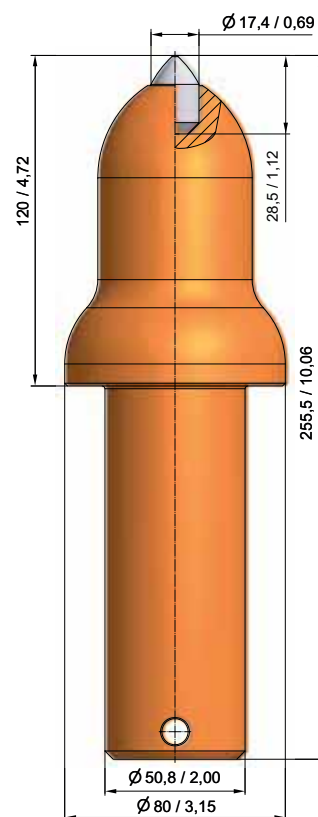

BSR109
BG51S-17.80120

5

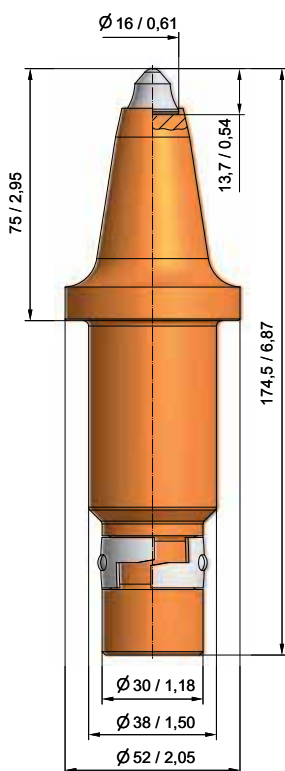

BLK10
B46K2L

10

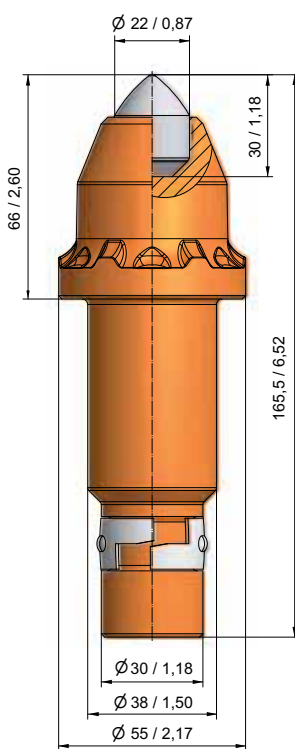

BLK12
BS38K-22.5566

10

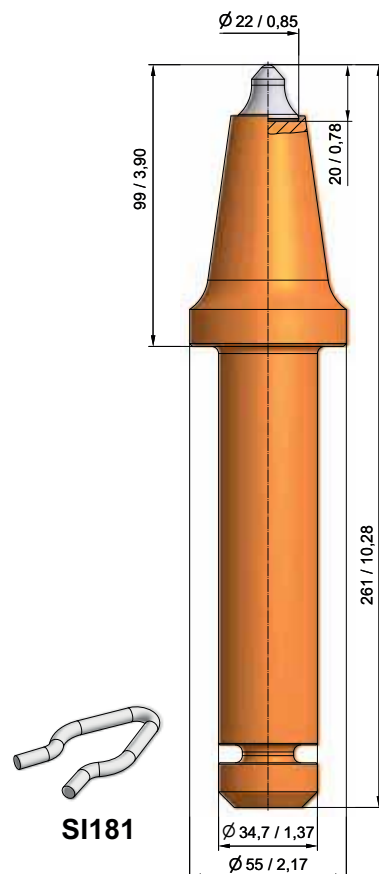

BSR153
BG35X-67.5599

5

Prihvat Ø38 - 1,5", tip Krummenauer

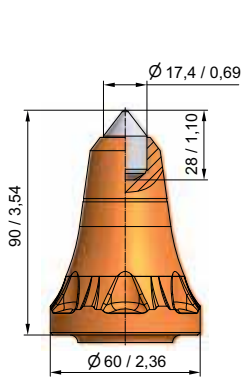

BKR27
BG38X-17.6090

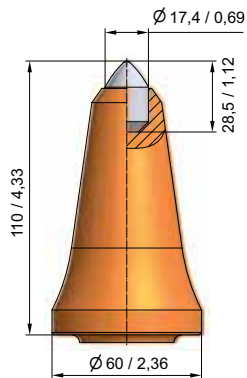

BKR07
BKR17.5LK110/S38

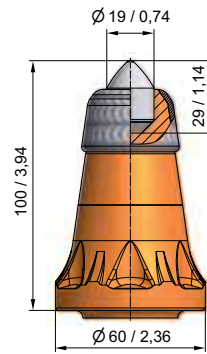

BKR25
BKR19LK100/S38-P

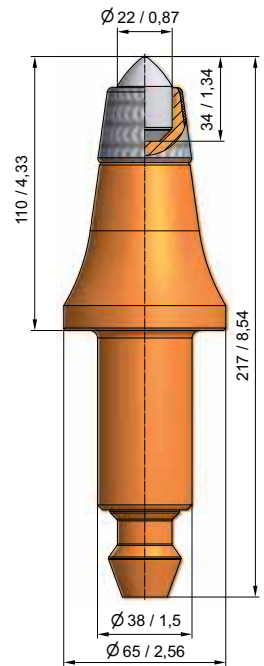

BKR29
BG38X-22.65110P



Prihvat Ø40 - 1,58", tip Krummenauer

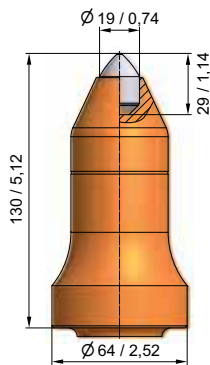

BKR26
BKR19LK130 64 / 2

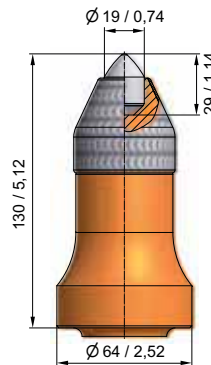

BKR24
BKR19LK130 64P

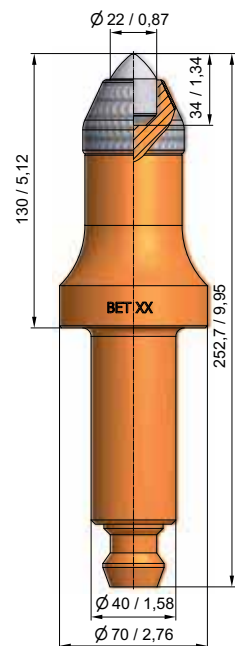

BKR28
BG40X - 22.70130P



Prihvat Ø43 / 35 mm - 1,7 / 1,38", visina glave 102 mm / 4,0"

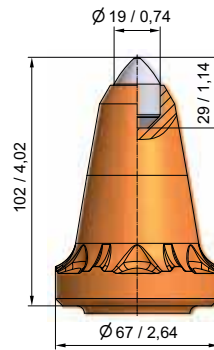
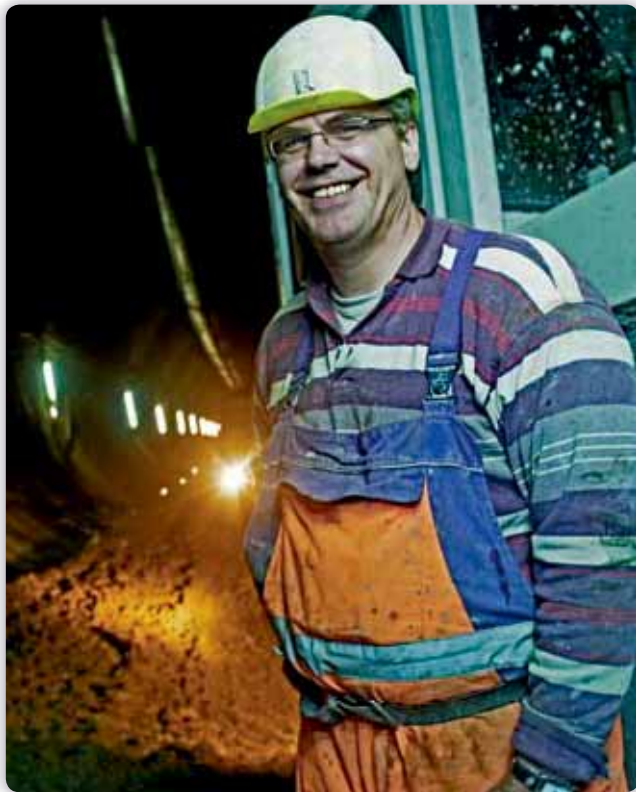

BSR204
BS43H - 19.67102H

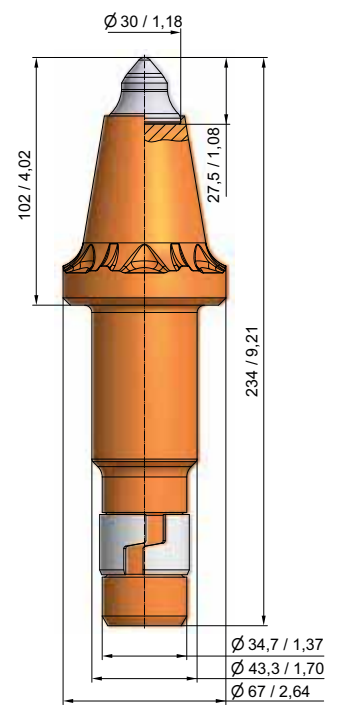

BSR181
BS43H - 69.67102A



Prihvat Ø43 / 35 mm - 1,7 / 1,38", visina glave 114 mm / 4,5"

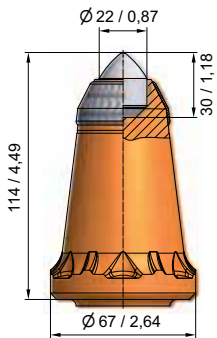

BSR178
BS43H - 22.67114P

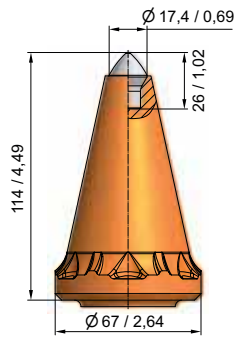

BSR191
BS43H - 70.67114A

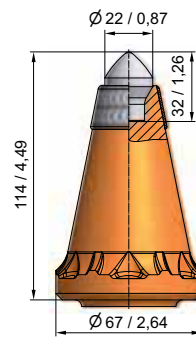

BSR206
BS43H - 73.67114P

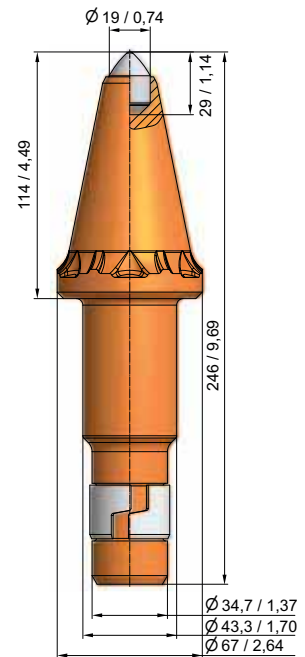

BSR182
BS43H - 19.67114

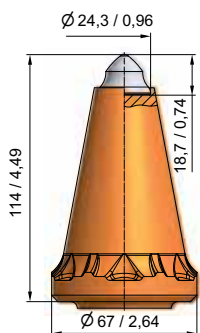

BSR205
BS43H - 68.67114

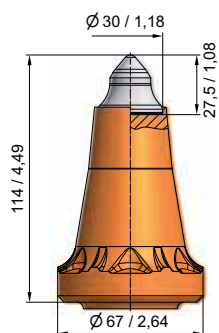

BSR203
BS43H - 69.67114



Prihvat Ø43 / 35 mm - 1,70 / 1,38"

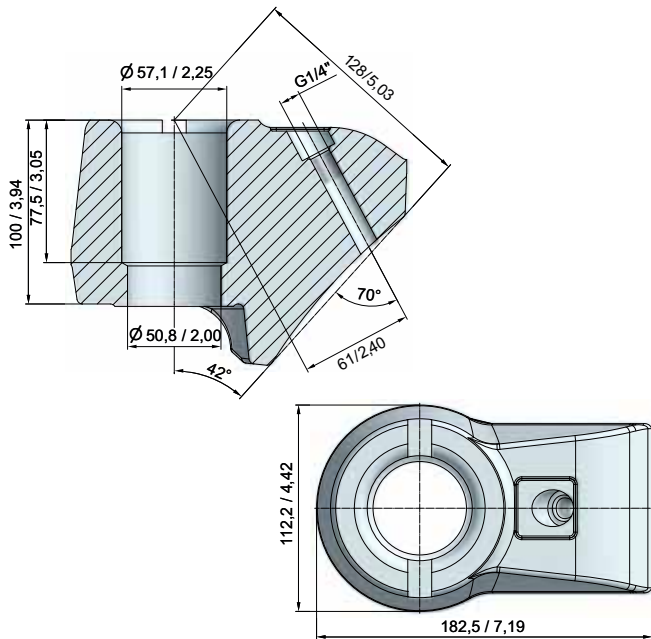

BHR159
B300

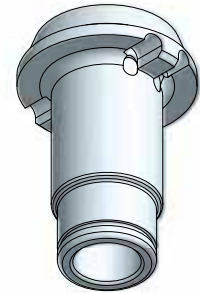
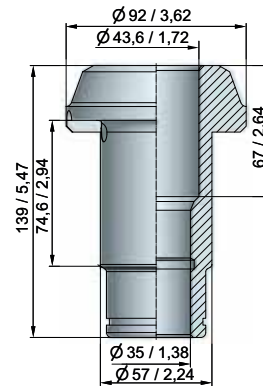

BR74
BR57- 44

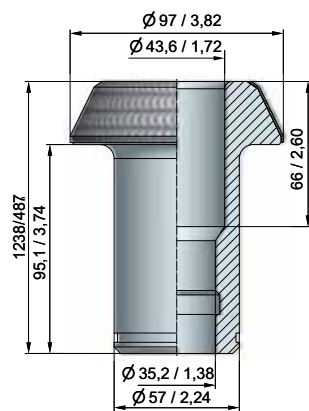

BR77
BR57- 44 -124 / P

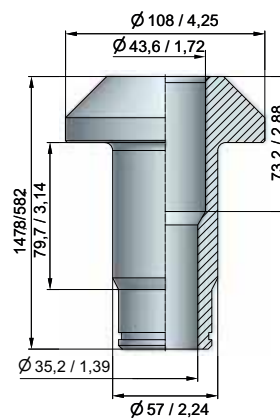

BR79
BR57- 44 -144



BZ40
Alat za vađenje klinova

Radialne oštrice - Radial pic

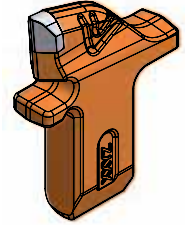
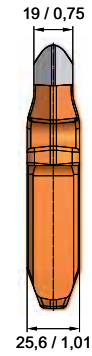
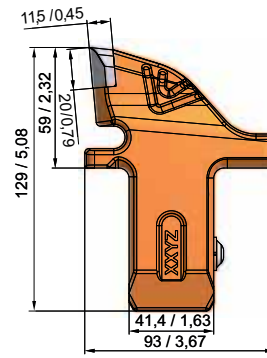
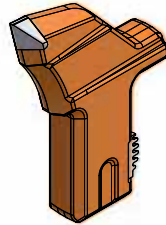
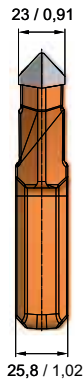
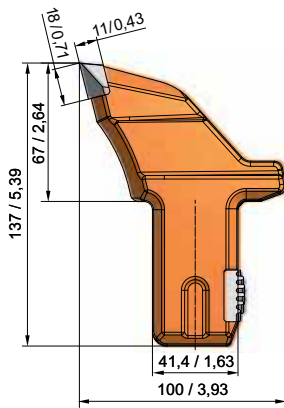

BF33
BF137x41.4x25.8

10

BF39
BF129x93x26

15

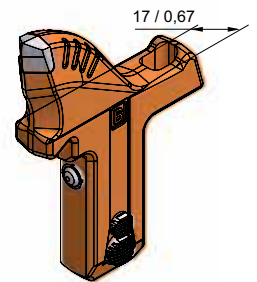
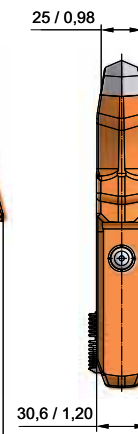
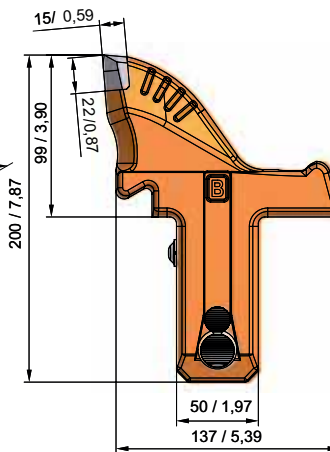
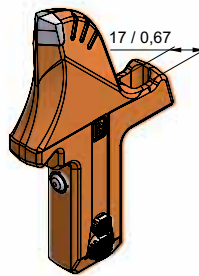
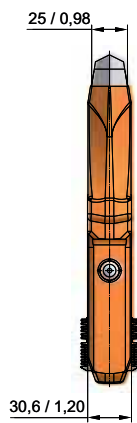
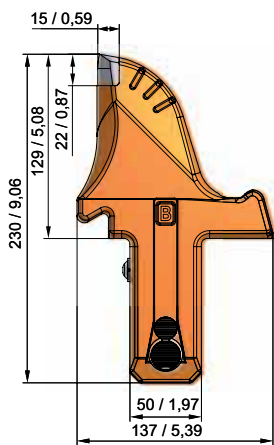

BF38
BF230x137x30.6

5

BF45
BF200x137x30.6

5

Krilasti zubi - Wing bit

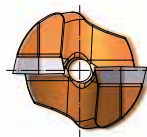
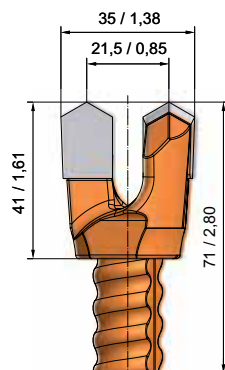

BD01
BD71-35

100

Iskop smjernih potkopa (mikrotuneliranje) - Microtunnelling

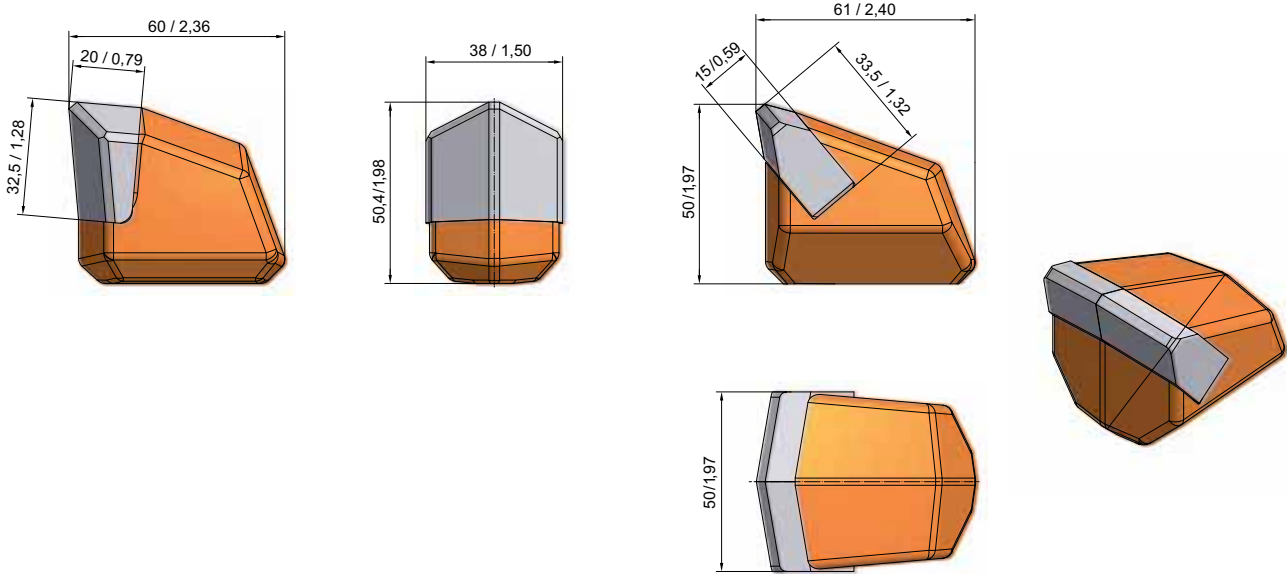

BFZ35M
BFZ38 / M

25

BFZ51
BFZ51

20

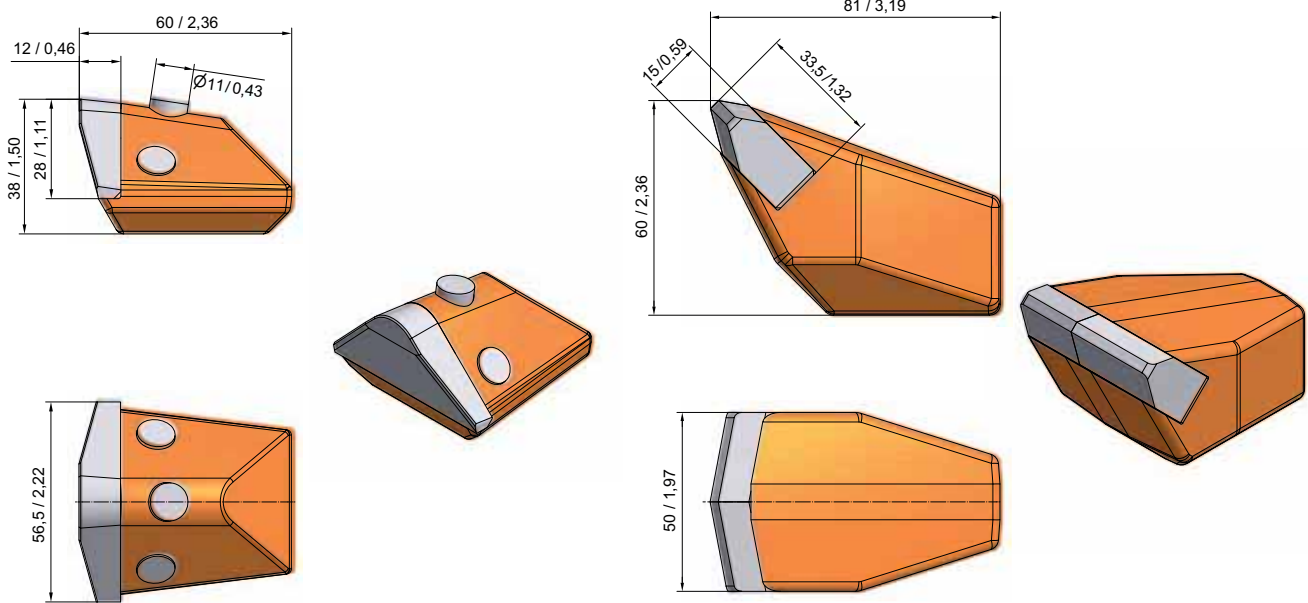

BFZ163
BFZ56

20

BFM08
BFM112x50 / S

15

Iskop smjernih potkopa (mikrotuneliranje) - Microtunnelling

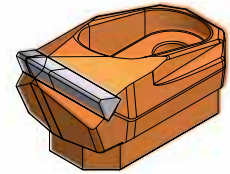
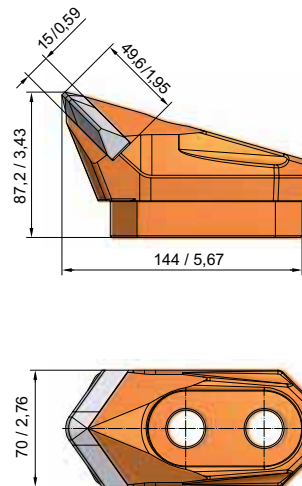
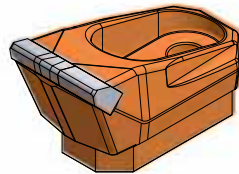
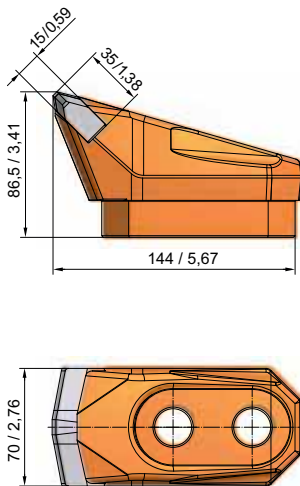

BFM07
BFM144x70



BFM16
BFM144x86x70

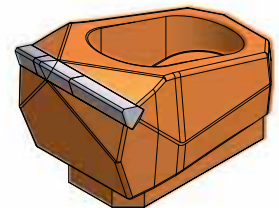
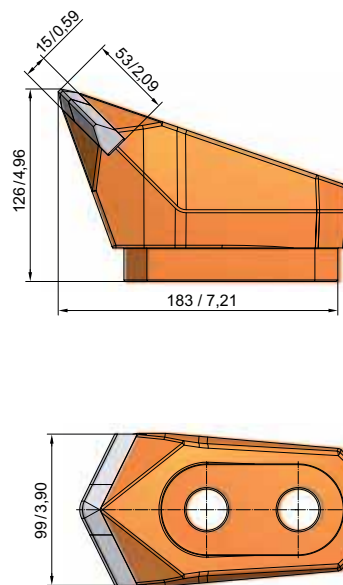
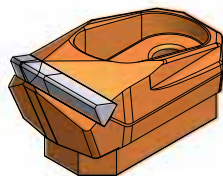
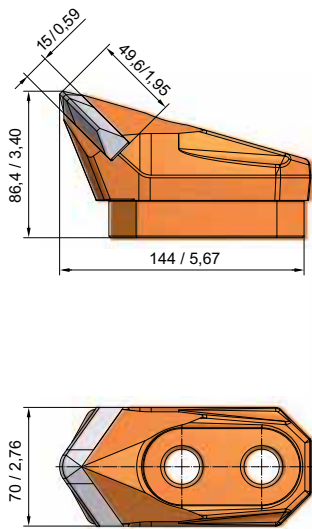

BFM70
BFM144x86x70 / 1



BFM71
BFM183x126x100

TBM alati (alati za strojeve za bušenje tunela) / Tools for TBM

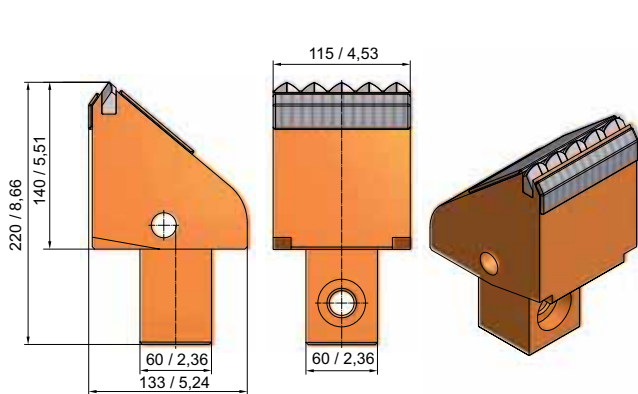

BFZ280
BFZ220x115

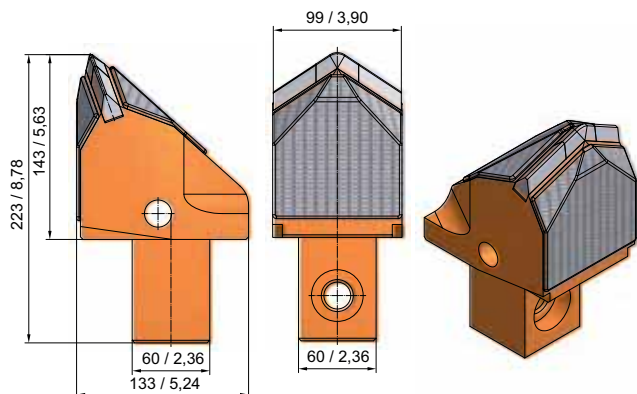

BFZ275
BFZ222,5x100

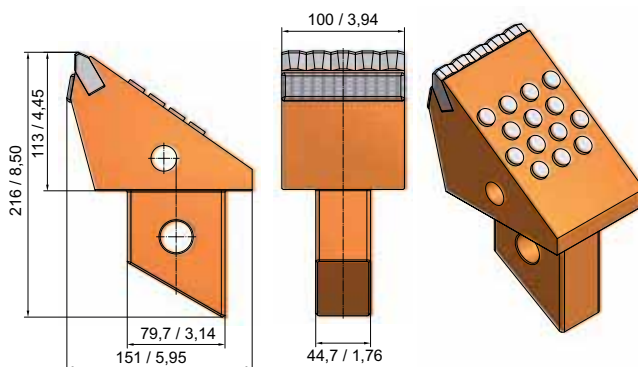

BFZ303
BFZ216x151x100

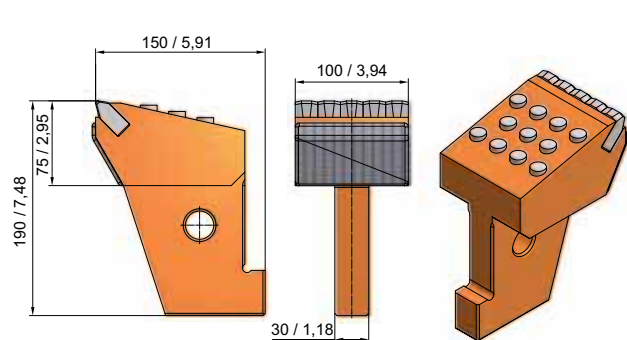

BFM77
BFM168x132 / B100

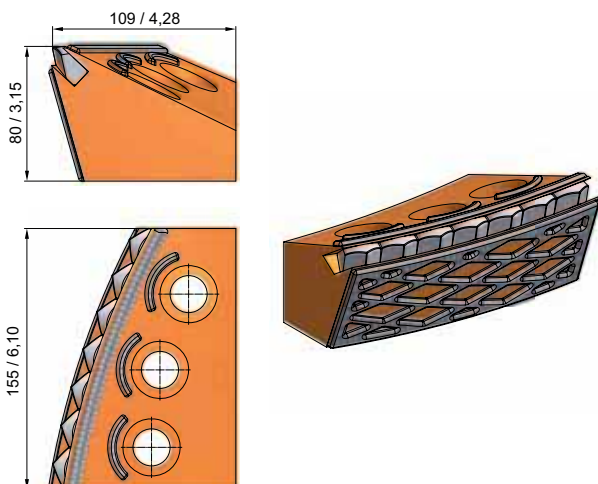

BRS13
BRS155x110x80 R

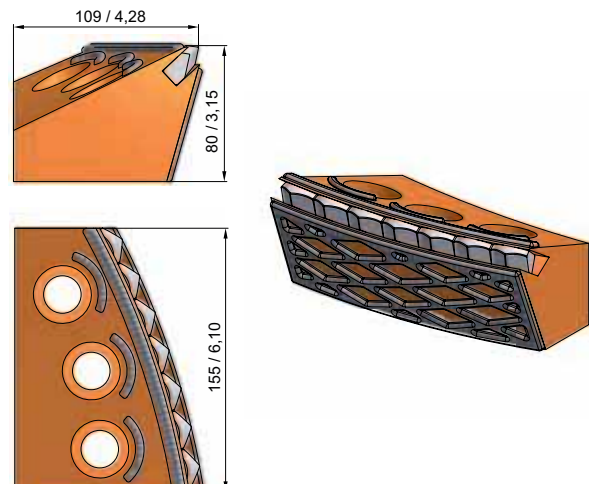

BRS14
BRS155x110x80 L

Vijci za zavarivanje s jezgrom od tvrdog metala / TungStuds

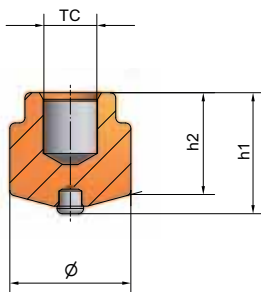

h_1 : visina prije zavarivanja
 h_2 : visina nakon zavarivanja

Za dodatne informacije pogledajte:
www.vorax.hr ili
www.betek.de/en/productprogramme/tungstuds

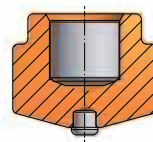
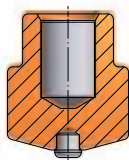
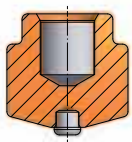

BTS01

\varnothing : 16mm
 h_1 : 16mm
 h_2 : 11-12mm
 TC: $\varnothing 7 \times 8,4$ mm

BTS02

\varnothing : 16mm
 h_1 : 19mm
 h_2 : 14 -15mm
 TC: $\varnothing 7 \times 11,4$ mm

BTS03

\varnothing : 19mm
 h_1 : 16mm
 h_2 : 10,5-11,5mm
 TC: $\varnothing 9 \times 8,4$ mm

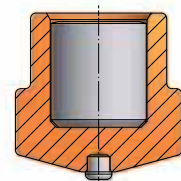
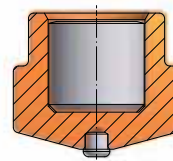
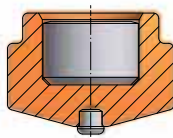
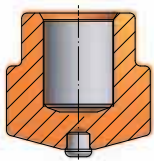

BTS04

\varnothing : 19mm
 h_1 : 19mm
 h_2 : 13,5 -14,5mm
 TC: $\varnothing 9 \times 12$ mm

BTS05

\varnothing : 22mm
 h_1 : 16mm
 h_2 : 10 -11mm
 TC: $\varnothing 12,6 \times 8,4$ mm

BTS06

\varnothing : 22mm
 h_1 : 19mm
 h_2 : 13 -14mm
 TC: $\varnothing 12,6 \times 12$ mm

BTS07

\varnothing : 22mm
 h_1 : 22mm
 h_2 : 16 -17mm
 TC: $\varnothing 12,6 \times 14$ mm



BETEK GmbH & Co. KG
Sulgener Str. 21 - 23
D-78733 Aichhalden
Germany
info@betek.de
www.betek.de

Predstavnik:

VORAX

Vorax d.o.o.

Vukovarska 68, 51000 Rijeka, HR

T: + 385 51 673 557

F: + 385 51 493 894

info@vorax.hr | www.vorax.hr

VORAX

experts in wear resistant technologies